

6 5 4 3 2 1

D

C

B

A

6 5 4 3 2 1

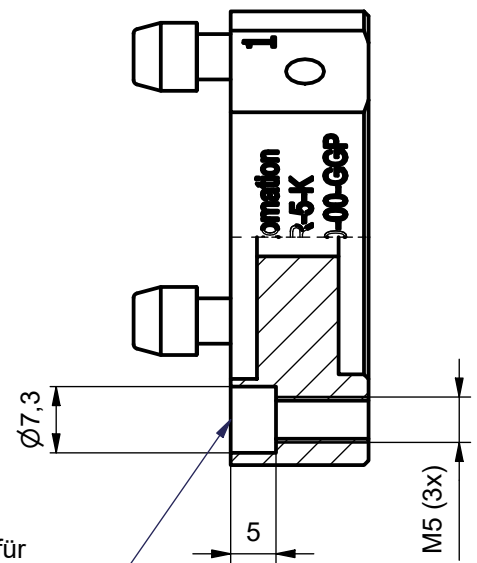

passend für
3x Zylinderkopfschraube
DIN912/ ISO4762 mit M5
suitable for
3x cylinder-head bolts
DIN912/ ISO4762 with M5

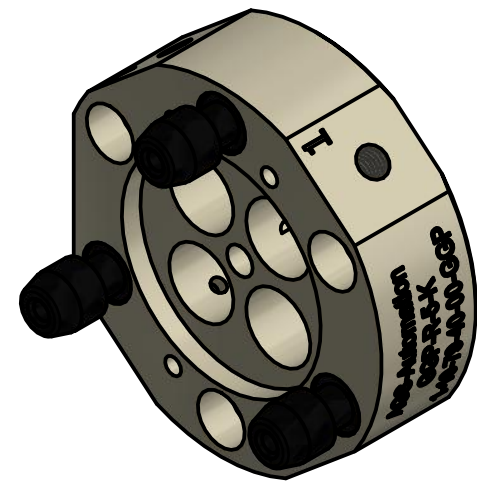
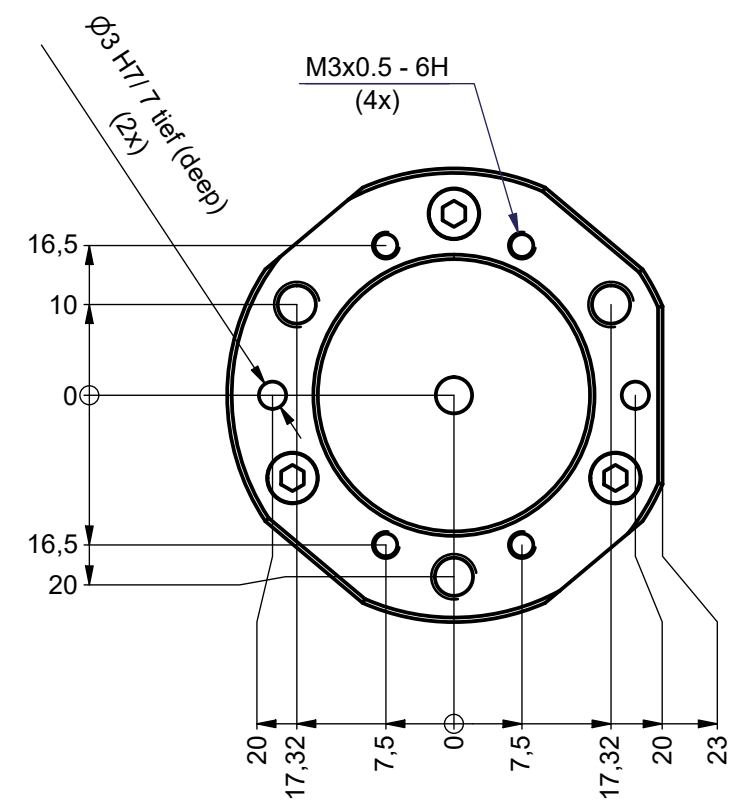
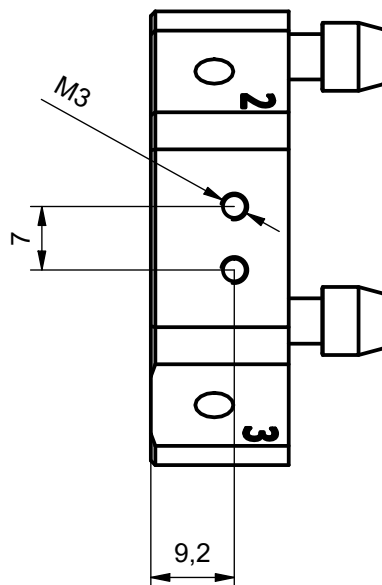
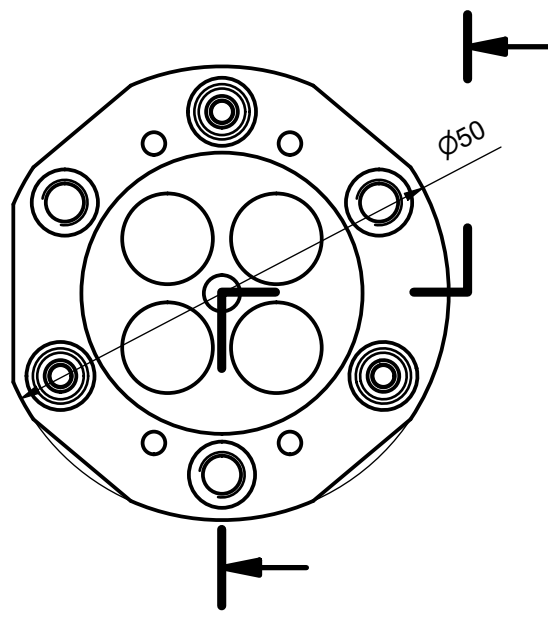

Bei den Belastungswerten handelt es sich um statische Werte:
max. Handhabungsgewicht 5kg
max. Drehmoment 30Nm
max. Biegemoment 15Nm

*Load values are statically determined:
handling weight only as guidance value 5kg
(direct at the Quick Change System)
maximal torque 30Nm
max. bending moment 15Nm*

Allgemeintoleranz nach DIN ISO 2768-1		Maßstab:		Gewicht:		
		Werkstoff:		Abmaße:		
		Datum	Name	Greiferwechselsystem GGP-R-5-K <i>EOAT Quick Change System Round - Fixed</i> GGP-R-5-K		
		Gezeichnet	22.12.2015			V.Klug
		Kontrolliert				
		Norm				
				1-10-79-50-00-GGP		
Status	Änderungen			Datum	Name	1 A3